

-  Aerospace
-  Automotive
-  Electronics
-  Hydraulics
-  Medical
-  Pneumatics

**Double Spindle  
Double Y-Axes  
Turret + Gang Tools  
Multi-Tasking Turning Center**

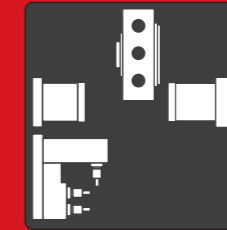

2 Y-Axes

**DY42  
DY52**



**MING YANG**  
MACHINERY CO., LTD.

TEL: +886-4-2537-7564 FAX: +886-4-2537-7645  
www.mym.com.tw sales@mym.com.tw



**Turning Precision  
Into Perfection**

### Front Machining

- BMT45 12-Stations
- Up to 24 Tools
- 7.5/11 kW Spindle Power
- 51 mm Through Hole

### Back Machining

- Gang Tools Slide: 14 Tools
- 3 Cross Live Tools
- 3 Face Live Tools
- 3 OD & 5 ID Tools

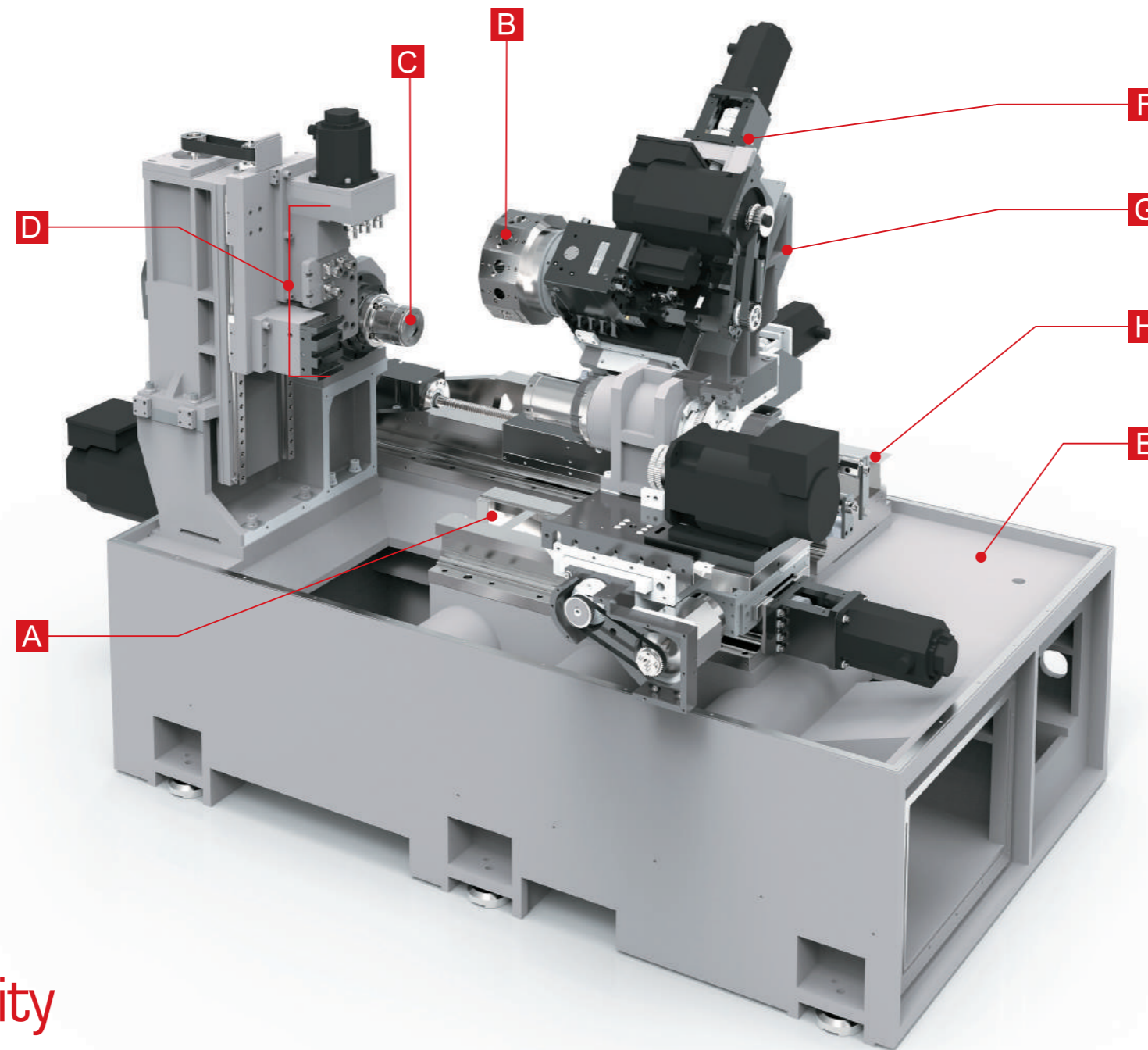

## Key Features

- A** Boxways on all axes are oversized and precision ground to a near mirror finish for smooth, fast precision movements providing dynamic rigidity & heavy-duty cutting ability
- B** The main turret has 12 stations. With multi-tool holders up to 24 tools can be equipped. Driven tools at all 12 stations are possible.
- C** Heavy-duty precision spindle design for enhanced thermal stability & power
- D** Y2-Axis gang tool slide 14 tools: 3 Cross, 3 Face live tools, 3 OD & 5 ID tools for complex back machining & superimposed cutting that reduces cycle times. The slide is on precision linear guides for fast & accurate machining
- E** Meehanite cast material is used and stress relieved to provide the best possible rigidity and vibration dampening base for machining parts with excellent surface finishes
- F** Y1-Axis travel +/- 35mm is supported by two slides, distributing the machining force evenly to ensure accuracy and rigidity
- G** 45 degree wedge design for fast chip flow and removal from the machining area for a thermally stable work platform
- H** Z-axis is equipped with precision high-rigidity 32mm ball screws & all other axes use 28mm ball screws to ensure fast feed rates and extended long-term durability for trouble free machining

## Capabilities

This multi-tasking turning center is an advanced machine designed to process precision complex parts in one setup.

## Power & Versatility

It has Double Spindles, a BMT 12 station Turret and a 2<sup>nd</sup> Y-Axis for back machining with 14 tools for a total capacity of up to 38 tools. This solution with superimposed cutting is a powerful combination of precision and two Y-axes for machining of complex workpieces with extremely fast cycle times.



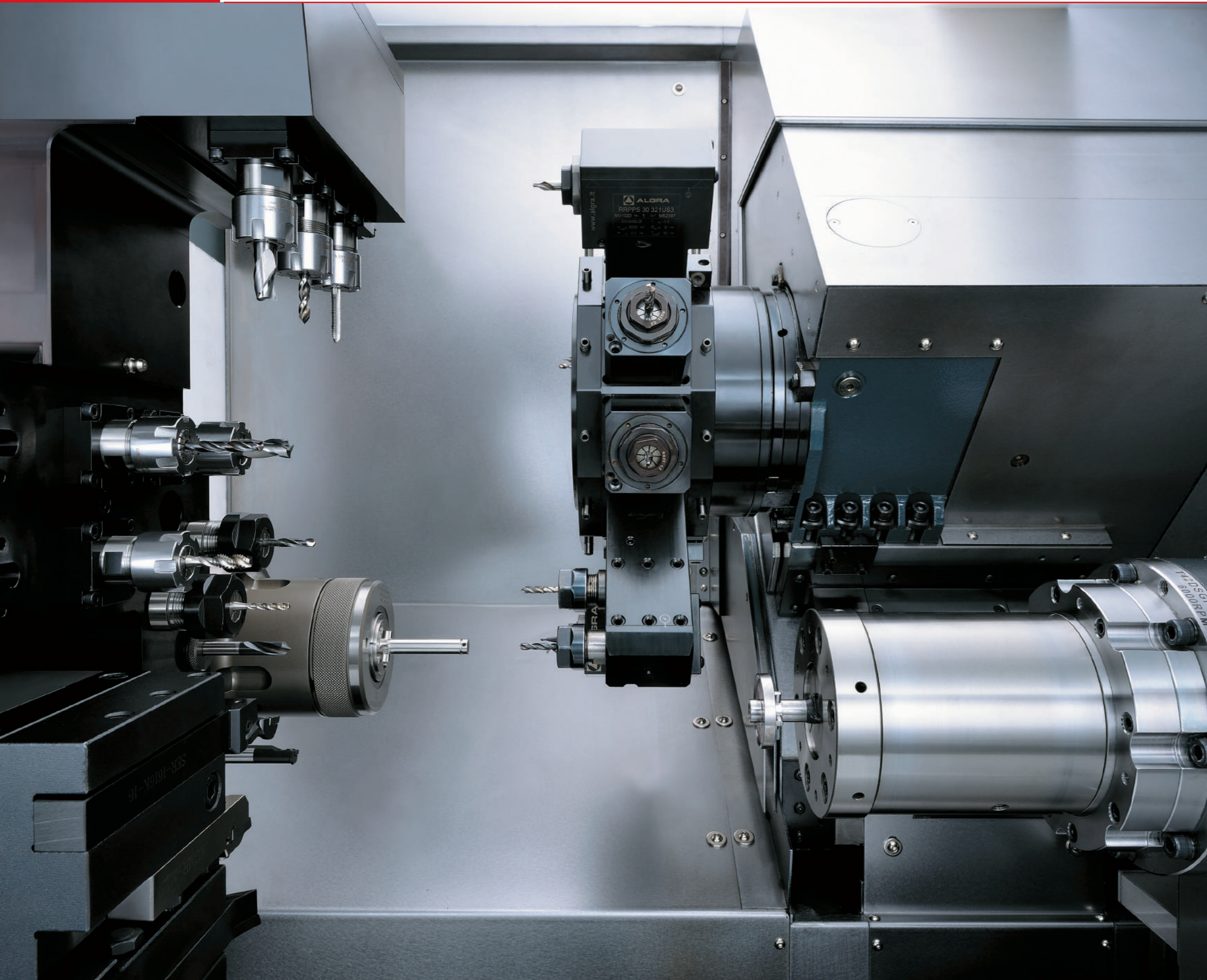

### SAUTER BMT45-12 Stations Main Turret

The main turret has 12 stations, but with multi-tool holders up to 24 tools are possible. Fanuc Alpha 2 motors provide driven tools up to 6000 rpm with high power and speed. Bidirectional turret indexing allows the shortest path to the next tool for faster cycle times. A 20 bar high pressure coolant system provides fast chip removal and longer tool life.

#### BMT45

- Fanuc Alpha 2 Motor-High torque, resolution & precision
- Driven tools: 2.2/3.75 kW & 23.5 N.m
- Optional 50/100 bar High Pressure Coolant Systems

### Gang Tool Slide & Driven Tools

The Y2 gang tool slide with a total of 14 tools can shorten machining times while also allowing for unparalleled back machining of complex workpieces. Cycle times can also be significantly reduced with superimposed cutting. High power and torque Fanuc Alpha 8 6000rpm servo motors can power through the most demanding parts.

- Fanuc Alpha 8 Motor-High torque, resolution & precision
- Driven tool power: 2.2kW & 22Nm
- 3 Cross & 3 Face live tools
- 3 OD & 5 ID tools

### Y-Axis Enhanced Machining Capability in One Setup Speed, Precision & Complex Parts



#### SAUTER BMT45 Turret (Y1-Axis)

- **24 Tools Possible**-12 station German branded turret for reliable heavy-duty cutting for non-stop production is equipped with half-indexing and fast tool changes of only 0.2 sec.
- **Fanuc Alpha 2** servos for driven tools up to 6000rpm for powerful high-performance cutting of the most difficult materials with ease and speed
- **20 Bar High Pressure Coolant** systems also provides fast chip removal and longer tool life necessary in for prolonged serial production. (Optional 50/100 bar)
- **Y1-axis Travel +/- 35mm**

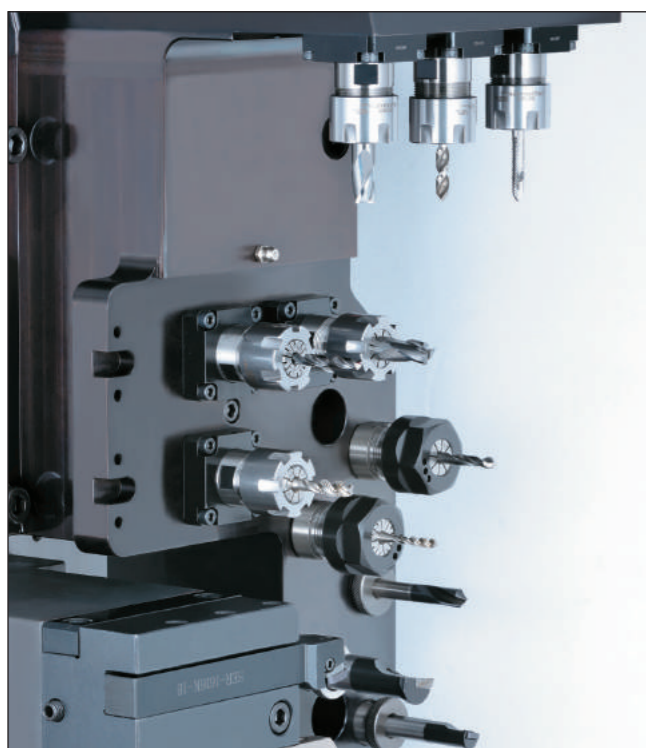

#### Back Machining Gang Tool Slide (Y2-Axis)

- **14 tools**-For back machining or complex workpieces, the added capability will shorten cycle time significantly.
- **6 Live Tools**-Live tools for Cross and Face milling
- **High Precision & Resolution** Fanuc Alpha 8 6000rpm servo motors can power through the most demanding parts with precision and high resolution.
- **Superimposed Cutting for High Productivity**-Cycle times can be significantly reduced with superimposed cutting & high power and torque
- **Y2-axis Travel 266mm**

Spindle 1, Turret 1 ID Turning

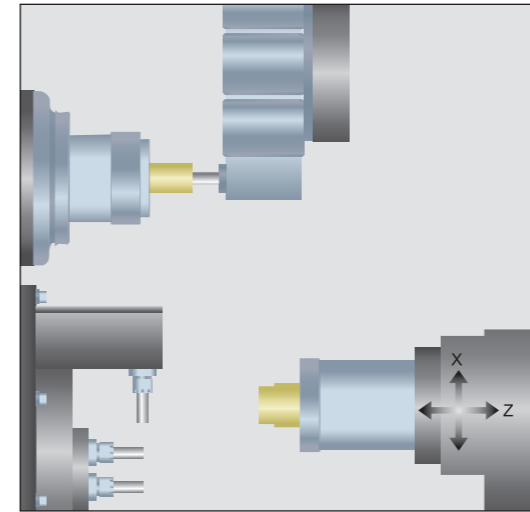

Transfer & Cutoff to Spindle 2

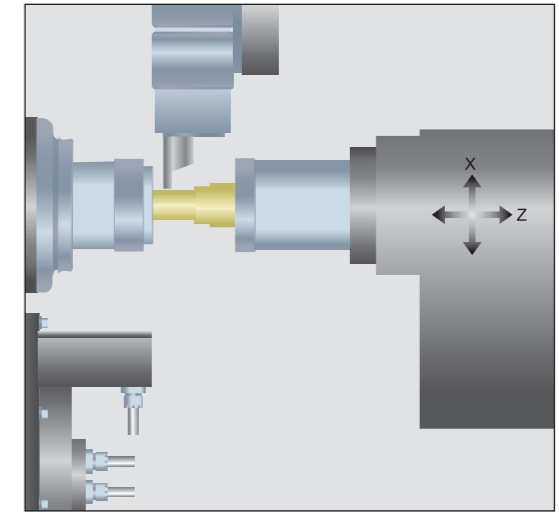

Superimposed Machining

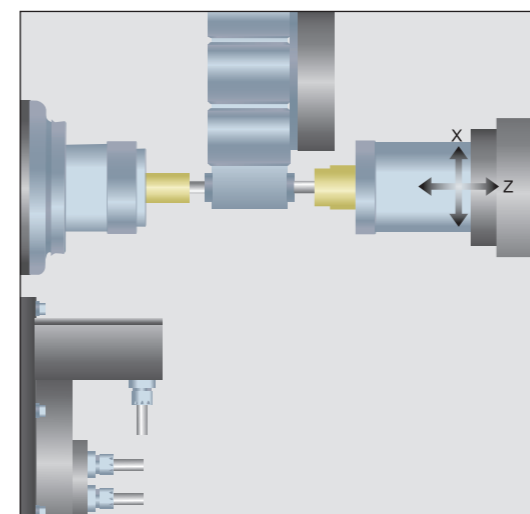

Turret 1 Back Machining

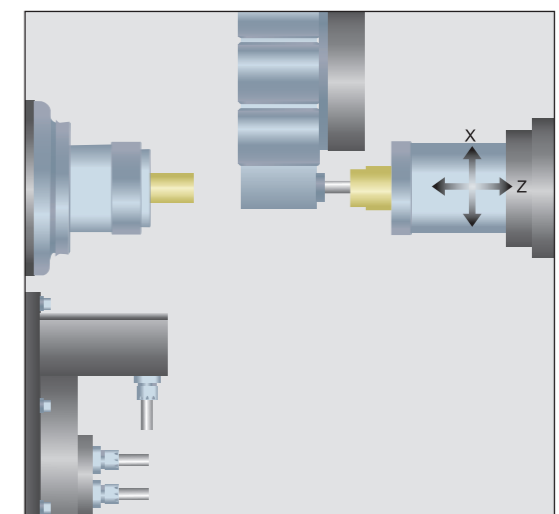

Spindle 1 & 2 Milling

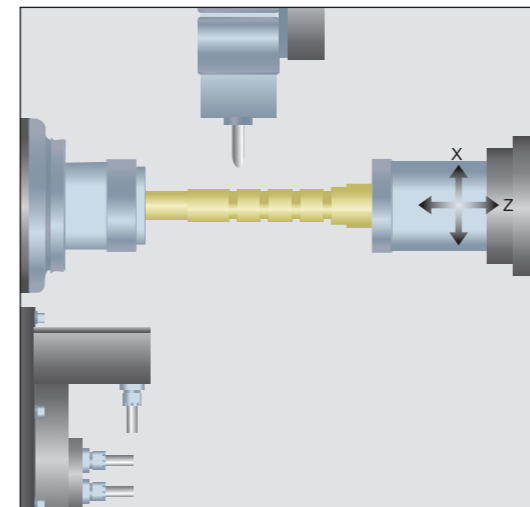

Turret 1 Milling & Y2 ID Turning

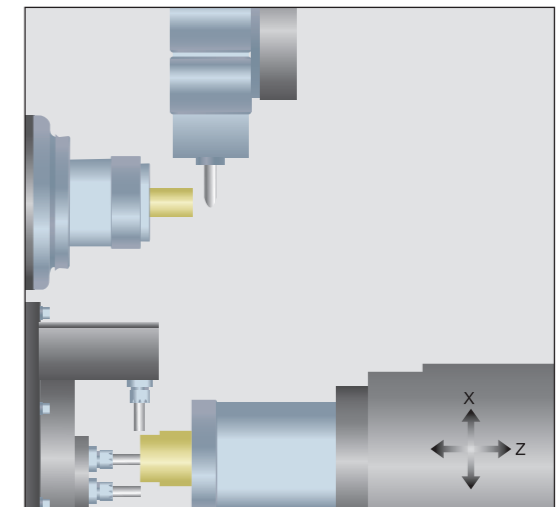

- Extremely rigid main and sub-spindles with purpose built roller bearings on the front and rear to concentrate power directly to the cutting surface and resist axial and radial forces
- Higher speeds and heavy-cuts are possible with this bearing arrangement
- Simultaneous independent machining of the front and back of the workpiece and C-axis with resolution of 0.001 degrees allows for complex contouring of parts

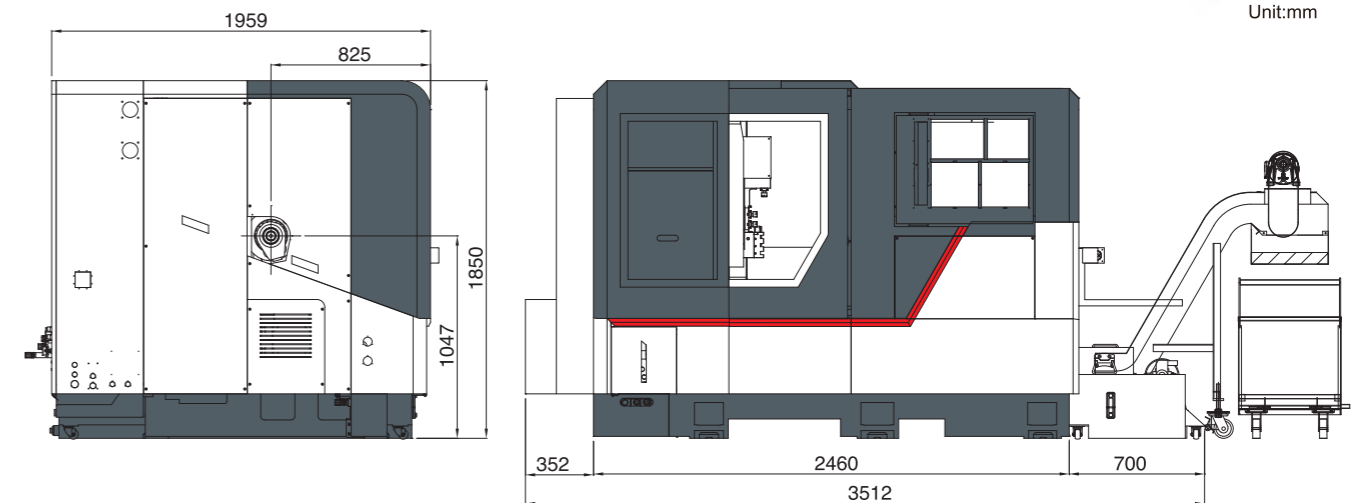
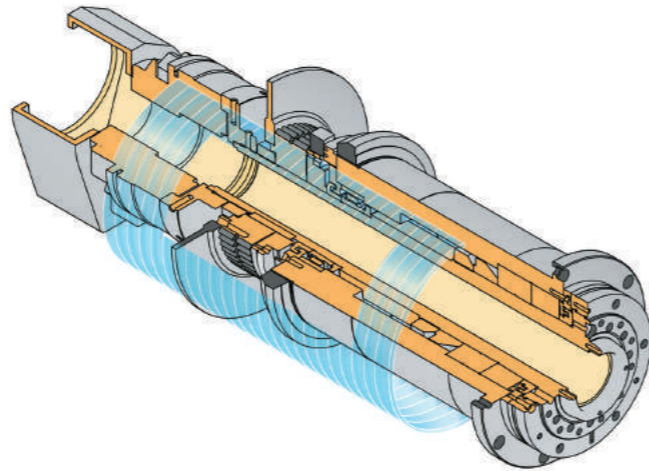

DY FANUC Main Turret Live Tool Torque

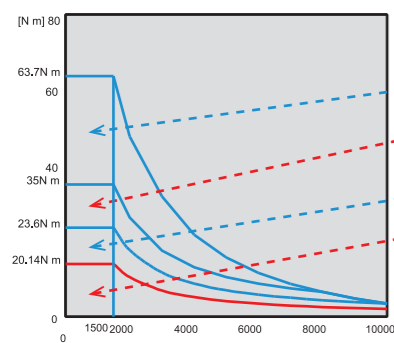

DY FANUC Sub-spindle Motor Torque

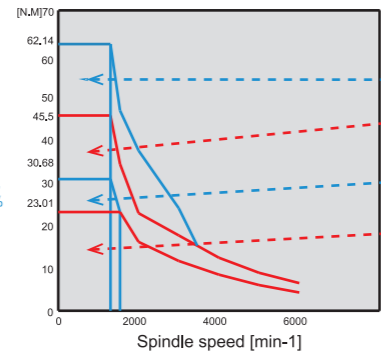

DT FANUC Main Turret Live Tool Torque

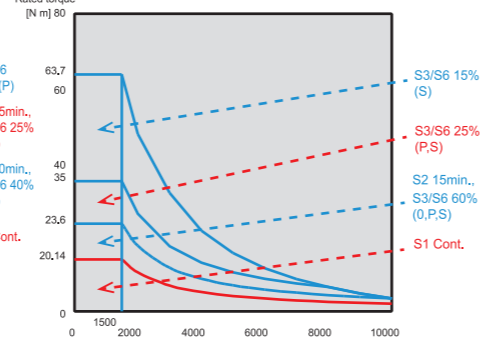

DY MITSUBISHI Main Turret Live Tool Torque

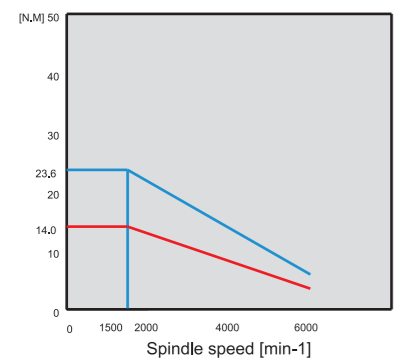

DY MITSUBISHI Sub-spindle Motor Torque

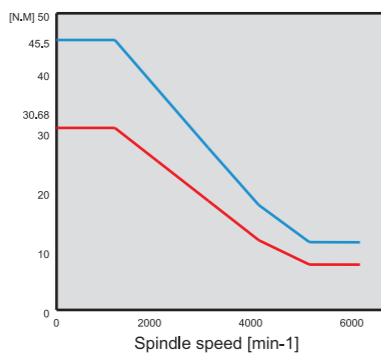

DT MITSUBISHI Main Turret Live Tool Torque

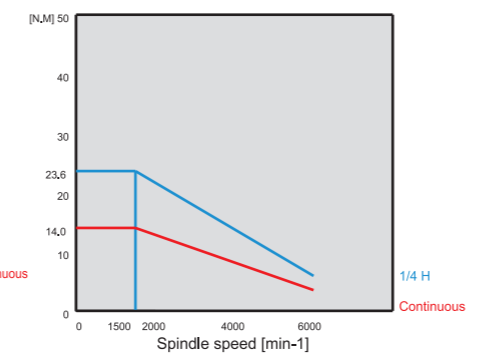

DY FANUC Y2 Live Tool motor Torque

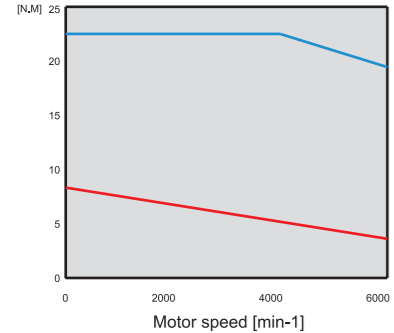

DY MITSUBISHI Y2 Live Tool motor Torque

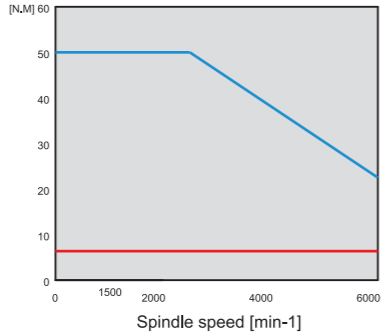

## Tool Interference Diagrams

Machining Zone

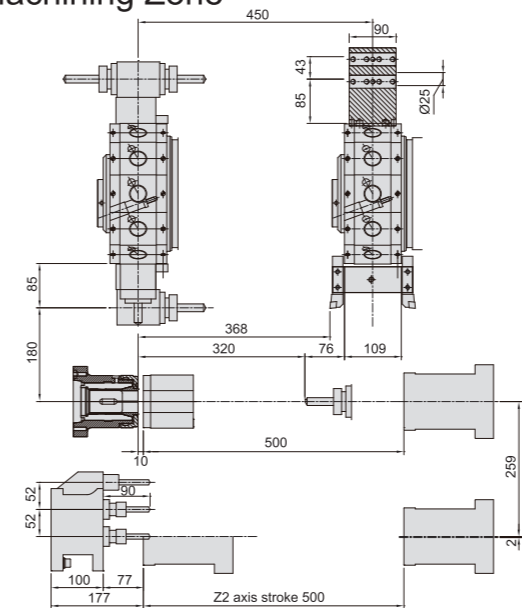

Tool Interference

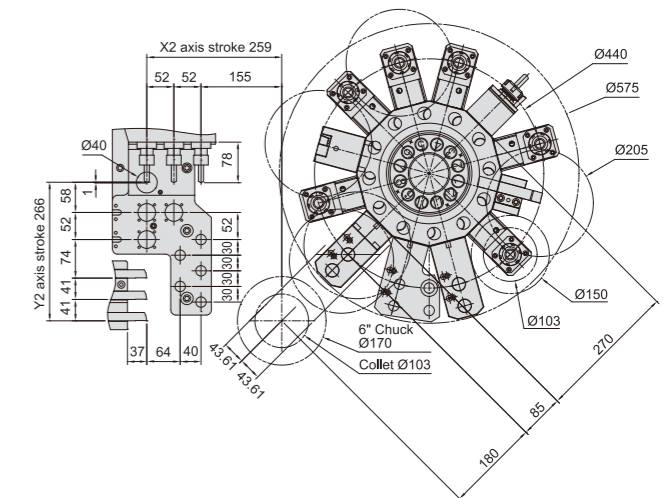

## Tooling System

Y2 Tooling System

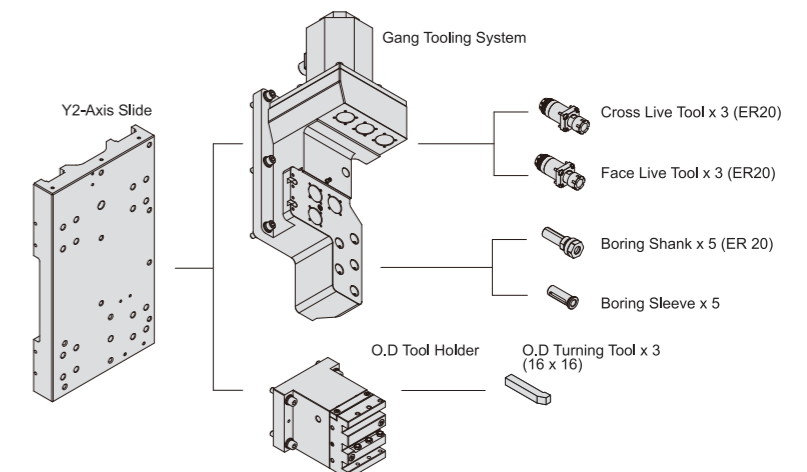

## VDI 30.12 Tooling System

Unit:mm

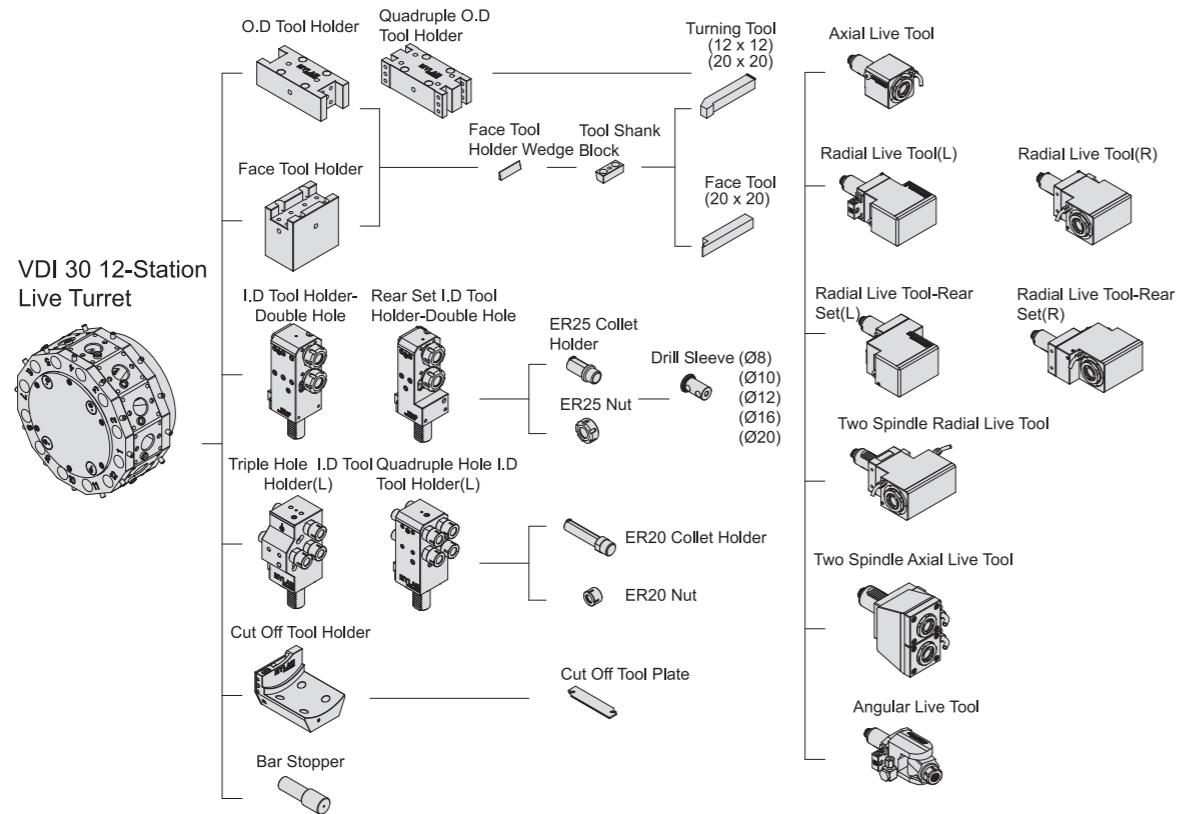

## BMT45. 12 Tooling System

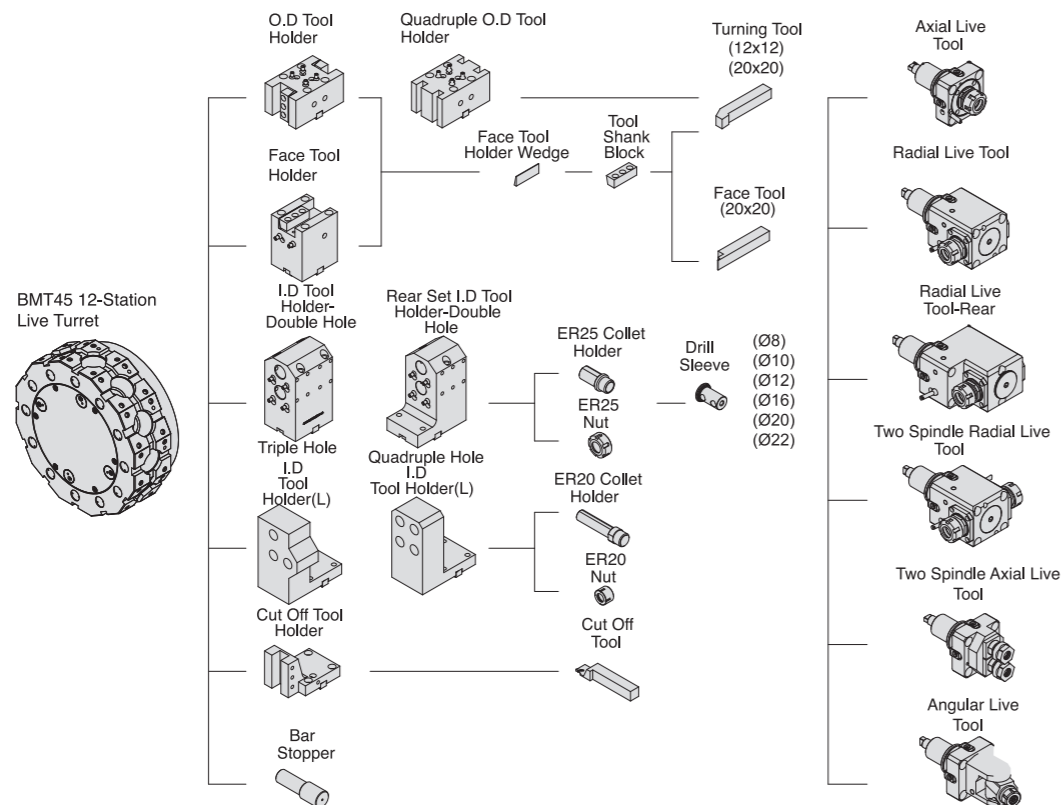

Item	Unit	DY42 Main Spindle	DY52 Main Spindle	DY42 / DY52 Sub spindle
Swing Over Saddle	mm	260	260	-
Chuck Type	mm	DIN173E	DIN177E	DIN171E / DIN173E
Max. Bar Turning Length	mm	135	150	60
Max. Turning Length	mm	350	350	-
Max. Turning	mm	150	150	135
Max. Turning Bar Diameter	mm	Ø42	Ø51	Ø32
X1 / X2 Axis Travel	mm	175 (X1)	175 (X1)	240 (X2)
Z1 / Z2 Axis Travel	mm	450 (Z1)	450 (Z1)	500 (Z2)
Y1 / Y2 Axis Travel	mm	±35 (Y1)	±35 (Y1)	266
X1 / X2 Axis Rapid Traverse	mm/min	18 (X1)	18 (X1)	18 (X2)
Z1 / Z2 Axis Rapid Traverse	mm/min	24 (Z1)	24 (Z1)	24 (Z2)
Y1 / Y2 Axis Rapid Traverse	mm/min	18 (Y1)	18 (Y1)	30 (Y2)
Spindle Nose	type	A2-5	A2-6	A2-4
Hole Through	mm	55	79	48
Spindle Speed	rpm	50 - 5000	50 - 5000	50 - 5000
Spindle Motor Type	type	β8 / 12000i	β8 / 12000i	β3 / 10000i
Spindle Motor (Cont./15min)	kW	7.5 / 11 / 15	7.5 / 11 / 15	3.7 / 5.5 / 7.5
No.of Tool Stations	set	12	12	-
O.D. Tool Size	mm	20	20	-
I.D. of Boring Bar Holder	mm	25	25	-
Turret Indexing Time	sec	0.1 - 0.3	0.1 - 0.3	-
Tool Spindle Speed	rpm	6000	6000	-
Tool Spindle Motor Type	type	α2 / 10000i	α2 / 10000i	-
Tool Spindle Motor (Cont./30mins)	kW	2.2 / 3.7	2.2 / 3.7	-
Tool Spindle Torque (Cont./30mins)	mm	14 / 23.5	14 / 23.5	-
Drill Capacity	mm	Ø13	Ø13	-
Endmill Capacity	mm	Ø13	Ø13	-
Tap Capacity	mm	M8	M8	-
No.of Tool Stations	set	-	-	14
O.D. Tool Size	mm	-	-	16
I.D. of Boring Bar Holder	mm	-	-	20
Tool Spindle Speed	rpm	-	-	5000
Tool Spindle Motor Type	type	-	-	α8 / 6000i
Tool Spindle Motor	kW	-	-	2.2
Tool Spindle Torque	NM	-	-	22
Drill Capacity	mm	-	-	Ø13
Endmill Capacity	mm	-	-	Ø13
Tap Capacity	mm	-	-	M8
X1 / X2 Servo Motor	kW	1.8	1.8	1.2
Z1 / Z2 Servo Motor	kW	1.8	1.8	1.8
Y1 / Y2 Servo Motor	kW	1.8	1.8	0.75
Turret Servo Motor	kW	0.75	0.75	-
Coolant Pump	kW	0.9	0.9	0.9
High Pressure Cutting Fluid Pump	kW	0.4	0.4	-
Hydraulic Pump	kW	3.75	3.75	-
Parts Conveyor Motor	kW	0.03	0.03	-
Chip Conveyor Motor	kW	0.2	0.2	-
Lubrication Pump	kW	0.003	0.003	-
Oil Mist Collector	kW	0.75	0.75	-
Hydraulic Capacity	Liter	55	55	-
Lubrication Tank Capacity	Liter	2	2	-
Coolant Tank Capacity	Liter	250	250	-
Machine Dimension (W x D x H)	mm	2660x1960x1850	2660x1960x1850	-
Machine Weight	kg	5350	5400	-

### Standard Accessories:

- Fanuc Controller
- Collet Chuck
- Workpiece Ejector
- 12-Station Power Turret
- Gang Tool System
- Auto Lubrication System
- Coolant System
- Sub-Spindle Inner Coolant & Air Blow
- Coolant Level Sensor
- Auto Power Shut-Off
- Signal Tower
- Parts Catcher
- Parts Conveyor
- High Pressure Coolant System (20 Bar)

### Optional Accessories:

- Live Tool Holder
- Static Tool Holder
- 6" Power Chuck for SP1
- 5" Power Chuck for SP2
- Air Blow for SP1/SP2
- High Pressure Coolant System (50 Bar/100 Bar)
- Chip Conveyor
- Oil Mist Collector
- Bar Feeder
- Transformer
- Regulator
- Mitsubishi Controller

We reserve the right to modify the above specifications without notice.