

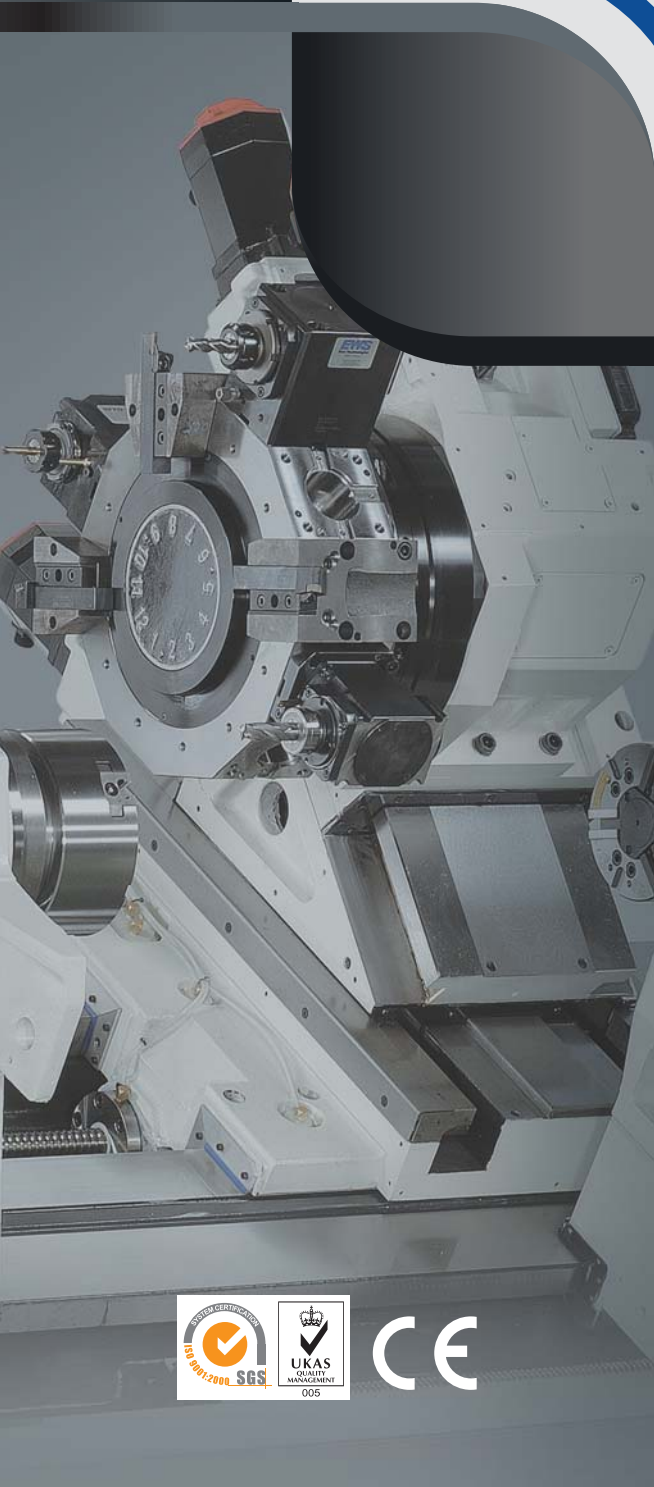

FocusCNC®

FNL-250Y/320Y/SY Series
FBL-250Y/320Y/SY Series
CNC Turning-Milling Machines Linear/Box Way



Multifunctional Turning and Milling Excellence

FNL-250Y/320Y/SY Linear Way Series

FBL-250Y/320Y/SY Box Way Series

CNC Turning-Milling Machines



Contents

02

Designed for Easy and Convenient Operations

03

Structure and Components

05

Servo Tailstock & Control

06

Processes and Workpieces

07

Optional Power Tool Holder

08

Tool System

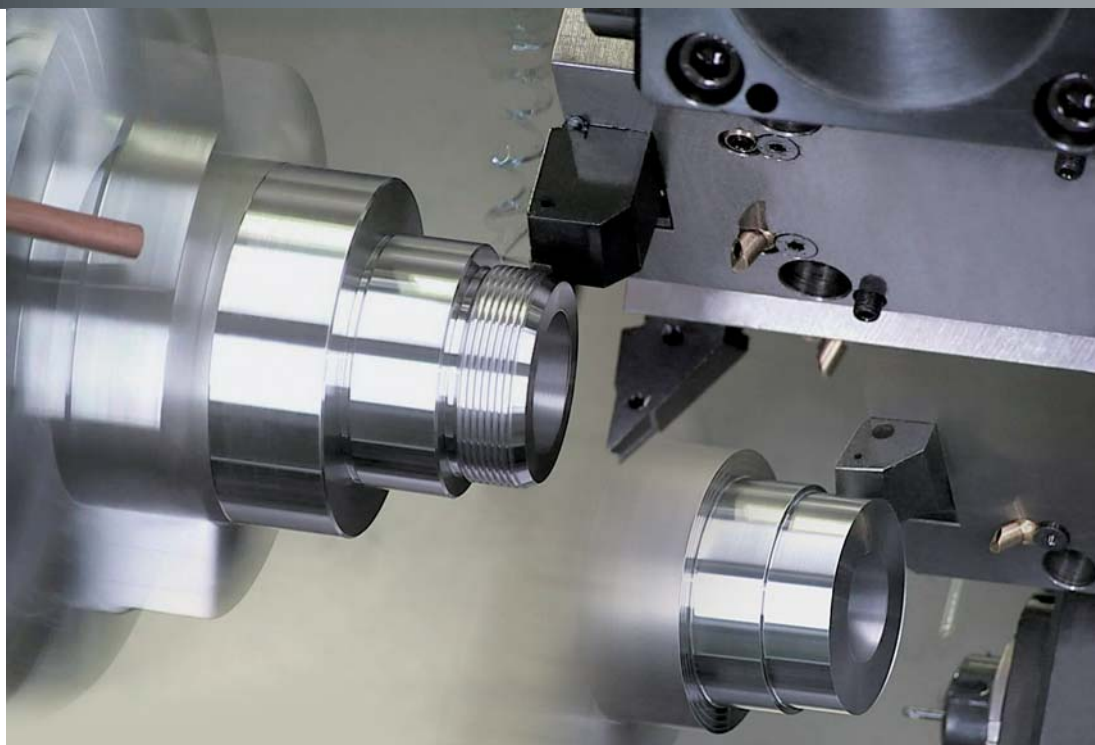

Designed for Easy and Convenient Operations

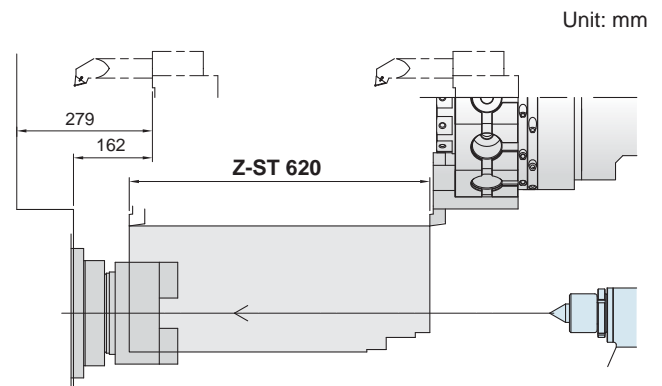
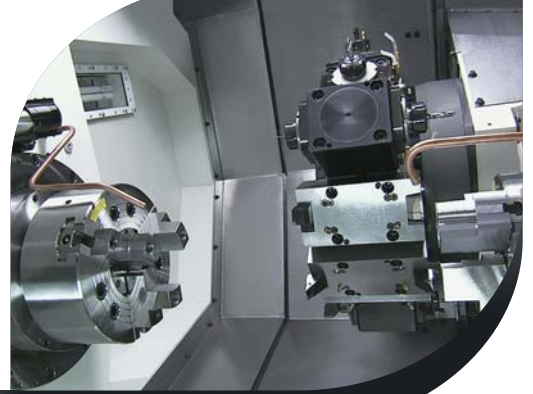

The space within the machining zone has been maximized to prevent any tool interference and provide the utmost flexibility and substantially reduce any chance of collision between the cutting tools and the machine.

<p>09 Tool Interference & Y Axis Milling Area</p>	<p>10 Spindle Torque Diagrams</p>	<p>11 FNL-250Y / SY & FBL-250Y / SY Machining Zone</p>	<p>12 FBL-320Y / SY & FBL-320Y / SY Machining Zone</p>	<p>13 Specifications</p>	<p>14 Standard & Optional Accessories</p>
--	--	---	---	-------------------------------------	--



Swiveling Control

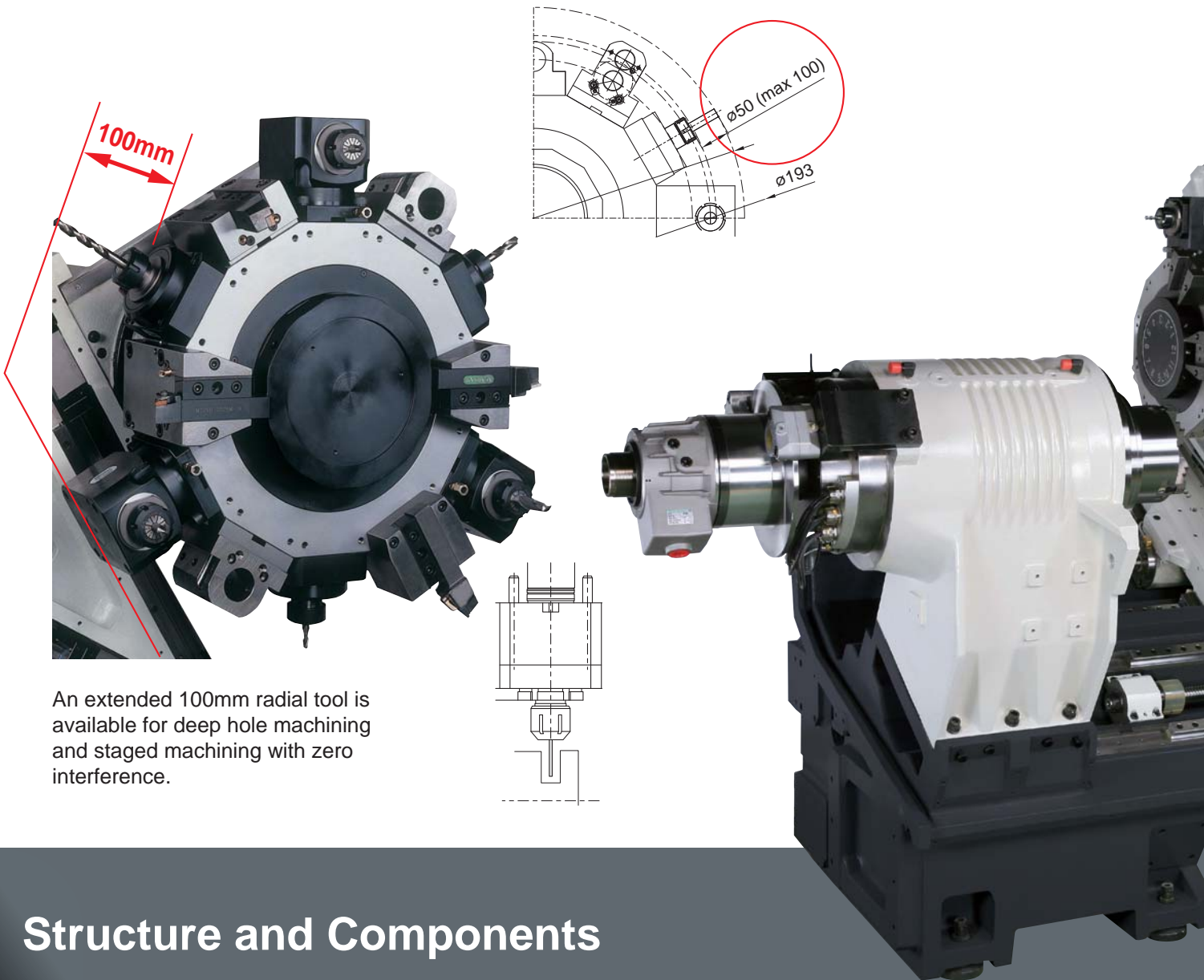

An extended 100mm radial tool is available for deep hole machining and staged machining with zero interference.

Structure and Components

Axis Pathways

Rexroth roller type linear guide ways ensure the highest accuracy is maintained during high speed machining. These high hardness guide ways provide excellent rigidity and impart very fast linear motion.

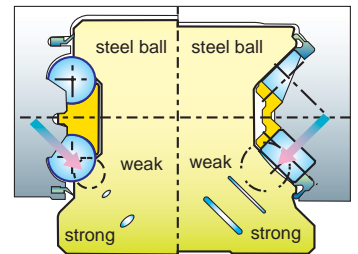
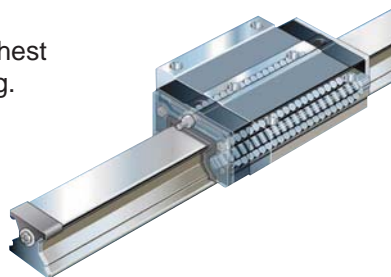

Contact between ball slideway and roller slideway.

Spindle Hole Capacity

The high speed high precision spindle combines front angular ball bearing and rear single row roller bearing to ensure optimum running and cutting precision even during extended periods of machining.

- The 8" spindle is designed with a spindle bore of 77mm and accepts bar stock to 65mm diameter.
- The 10" spindle is designed with a spindle bore of 88mm and accepts bar stock to 77mm diameter.

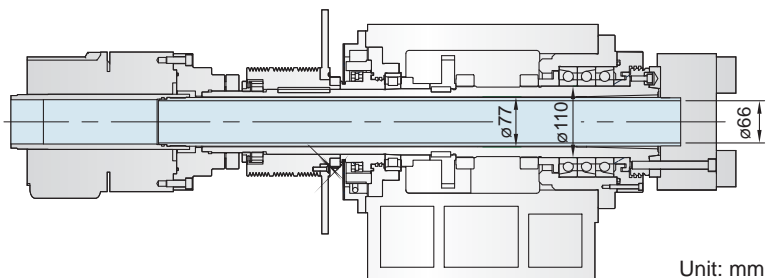

Unit: mm

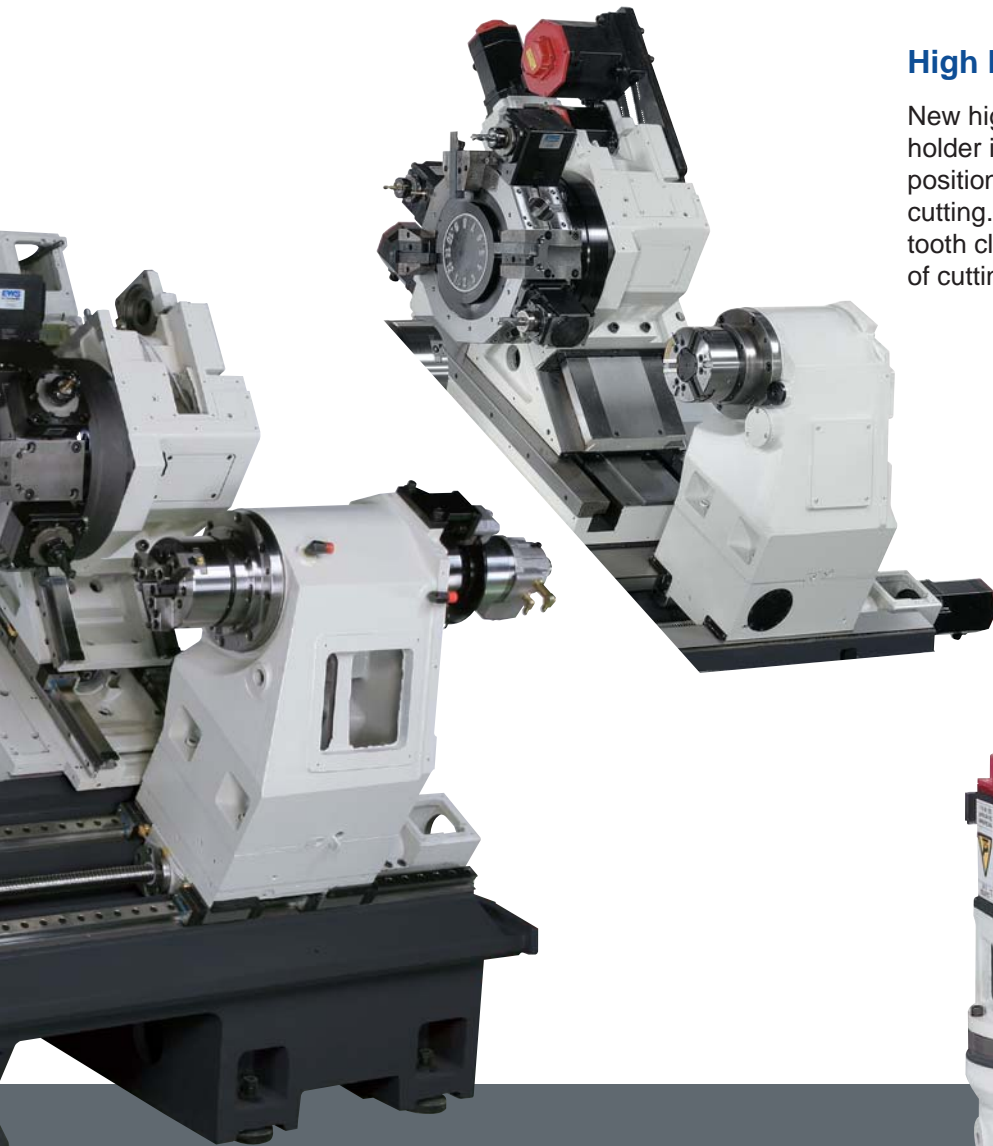

High Rigidity Power Turret

New high rigidity BMT power turret and tool holder is fixed using four bolts and a positioning key for the ultimate in stable cutting. This unit uses an oversized curved tooth clutch to enhance rigidity and accuracy of cutting tools during machining.

The high torque CF axis means stable operations with no vibration during dynamic milling.



High Precision Built in Spindle

- Built in main and sub spindles are available.
- Built in spindles do not cause the vibrations imparted by belt drives.
- Built in spindles offer lower inertia and quicker acceleration/deceleration.
- An oil cooler is standard on built in spindles for reduced thermal deformation.

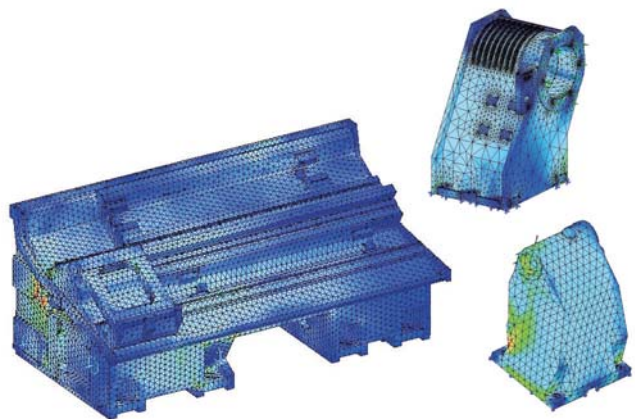
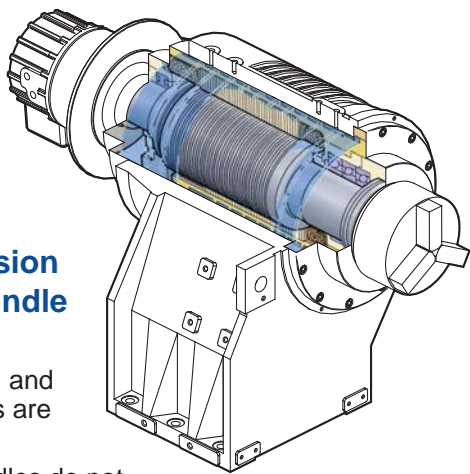

Optimum structural rigidity is achieved as all main structures undergo FEA (FEM) analysis. The sturdy 30 degree slant bed and base provide superior rigidity that does not deform, ensuring long term stability.

Servo Tailstock



Optional quill to fit a $\varnothing 50\text{mm}$ high speed drill with a 20 bar high pressure pump for high speed drilling is available.



Servo Tailstock Interface

Tailstock positioning and quill thrust force are simple to set up using the specially designed servo tailstock interface.

The high speed servo driven tailstock offers high speed high precision positioning and digitally controlled thrust force settings. Quill thrust force can be set according to part length & diameter. This results in reduced down time and increased manufacturing efficiency.



Control

Fanuc

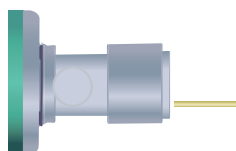
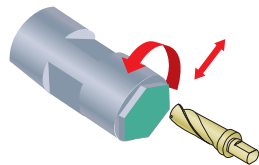
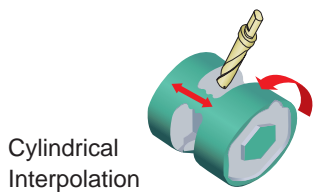

Manual Guide i
Conversational editing with 3D simulation available.

Siemens



Uses a 10.4" screen for easy operation. Optional Shop Turn function with integrated operating system. Finish programming without having to use G code.

- 2 window view dynamic simulation
- 3D finished part simulation
- 3D section view

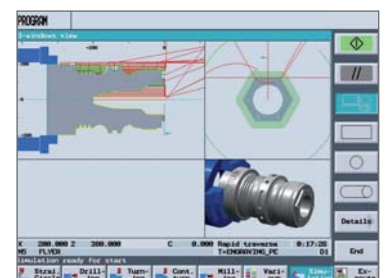

Processes and Workpieces



Automobile Parts
Aluminum Alloy



Motorcycle Parts
Aluminum Alloy



Power Tool Parts
S45C Medium Carbon Steel



Machine Parts
S45C Medium Carbon Steel



Motor Casting
Aluminum Alloy



Hydraulic Parts
Stainless Steel



Fitness Equipment Parts
Aluminum Alloy

Optional Power Tool Holder



Radial Power Tool Holder
ER40 ER32 ER25
6000rpm max turning speed



Axial Power Tool Holder
ER40 ER32 ER25
6000rpm max turning speed

Power Tooling Cutting Capabilities

α 12i 2.7kW 46Nm

Radial (X axis) Power Milling

Material: S45C
Tool dia. \varnothing 20 mm

Depth of cut	10 mm
Spindle speed	400 rpm
Feed rate	120 mm/min
M.R.R	24 cc/min



Radial Face Milling Tool Holder
Tool Clamping \varnothing 22 \varnothing 27
6000rpm max turning speed



Axial Face Milling Tool Holder
Tool Clamping \varnothing 22 \varnothing 27
3000rpm max turning speed

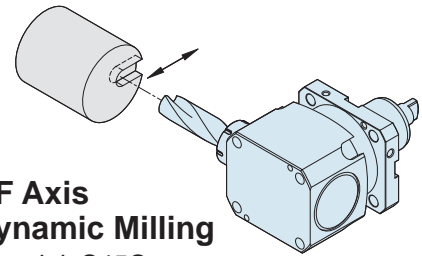

CF Axis Dynamic Milling

Material: S45C
Tool dia. \varnothing 20 mm

Depth of cut	8 mm
Cut radius	68 mm
Spindle speed	400 rpm
Feed rate	120 mm/min
M.R.R	19.2 cc/min



High Speed Radial Power Tool Holder
ER32 ER25
12000rpm max turning speed



High Speed Axial Power Tool Holder
ER32 ER25
12000rpm max turning speed

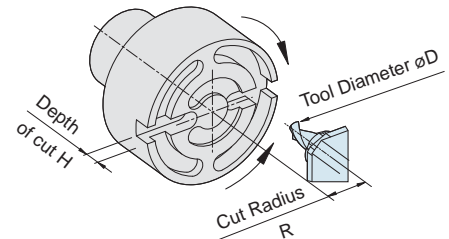

Power Drilling

Material: S45C

Drill dia.	20 mm
Spindle speed	577 rpm
Feed rate	100 mm/min
M.R.R	31.7 cc/min



Axial Two Head Power Tool Holder
6000rpm max speed

Live tool turret motor offers optional α 22i 4.5kW 55Nm for high torque output, with speed up to 6000rpm.

Power Tapping

Material: S45C

Tapping spec.	M3 x P0.5	M20 x P2.5
Spindle speed	1200 rpm	160 rpm

Tool System

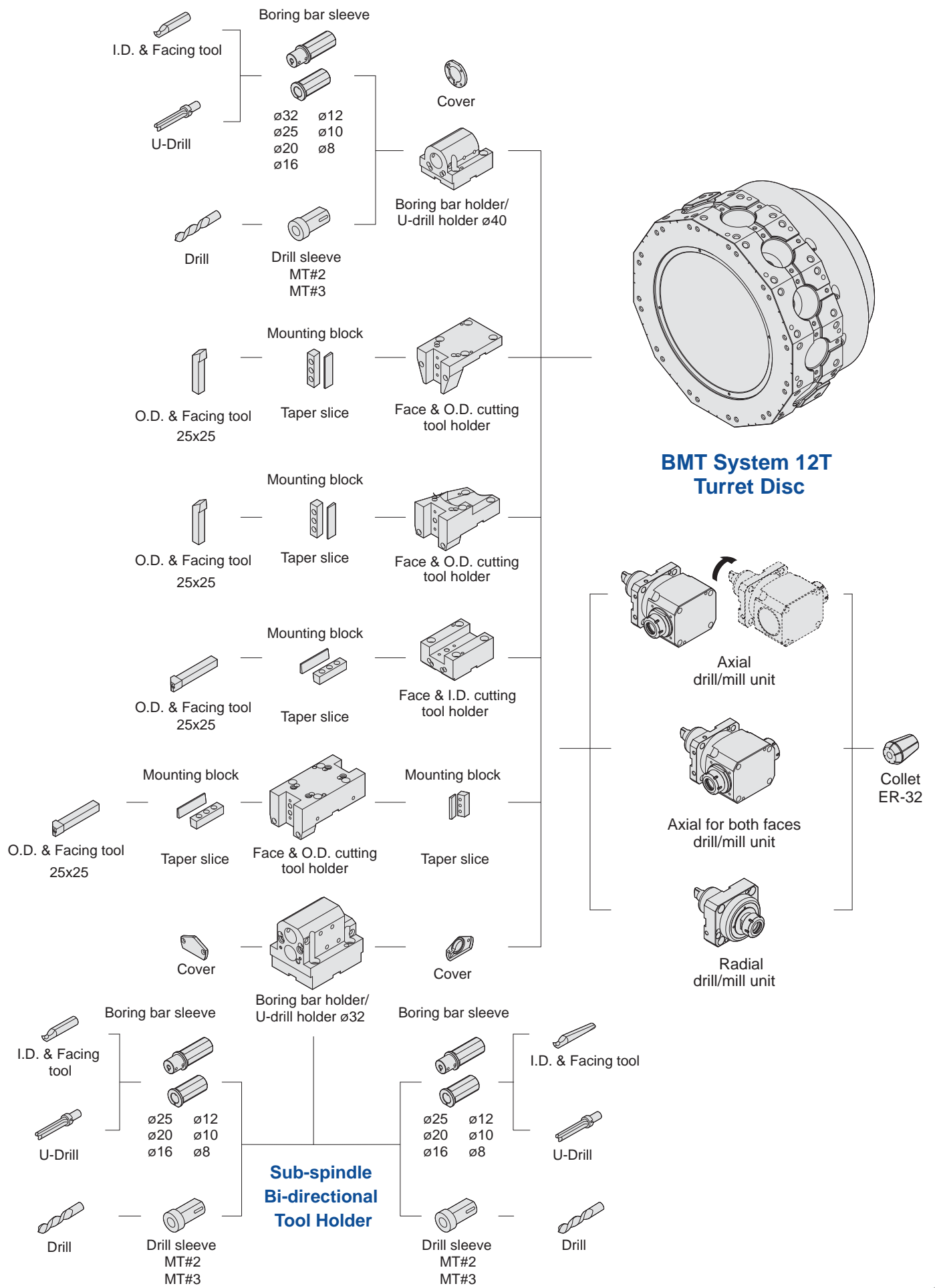

Tool Interference

Unit: mm

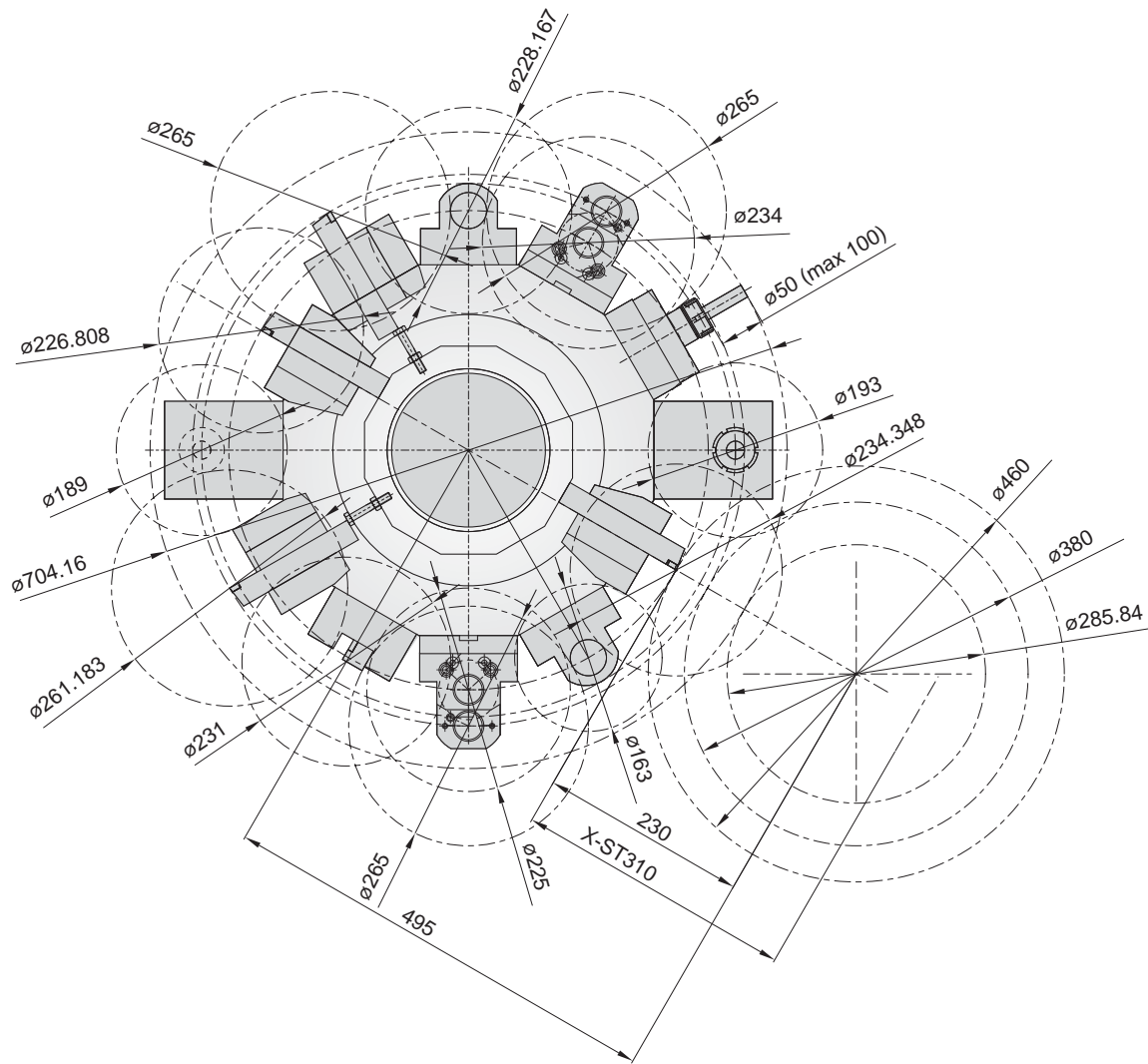

Y Axis Milling Area

Unit: mm

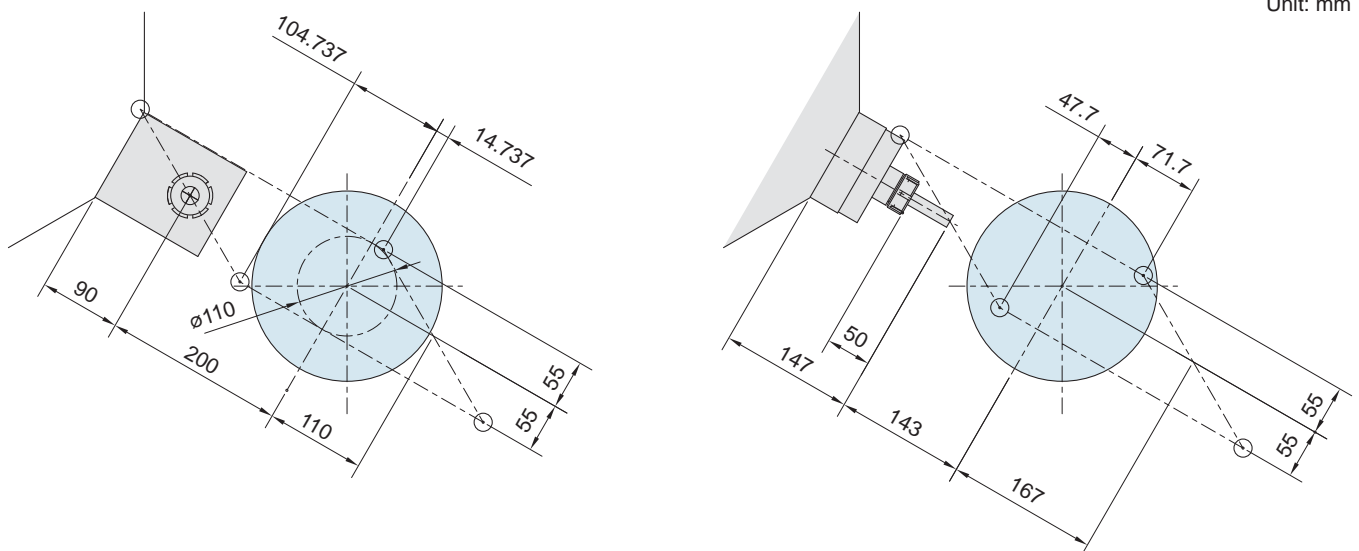

Spindle Torque Diagrams

Main Spindle (Belt)

FANUC 22/6000ip
High-speed

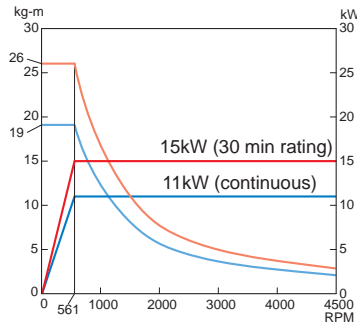

FANUC 22/6000ip
Low-speed

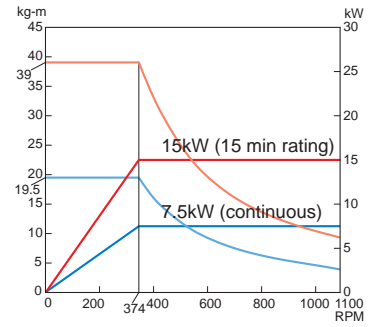

Main Spindle (Built-in)

FANUC 180M/6000iB
Low winding

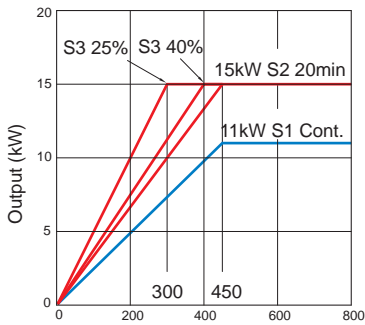

FANUC 180M/6000iB
High winding

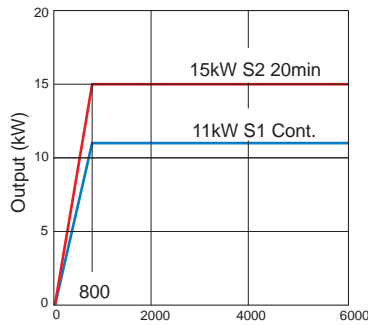

FANUC 180M/6000iB
Low winding

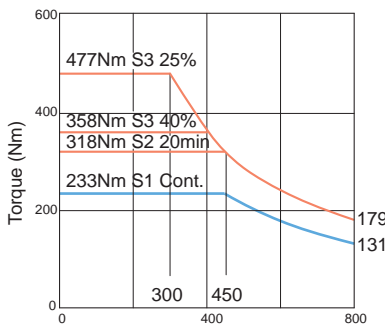

FANUC 180M/6000iB
High winding

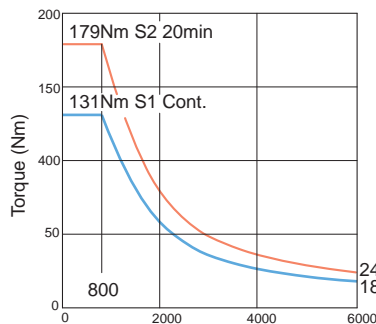

FNL-250SY / 320SY FBL-250SY / 320SY (Sub spindle)

FANUC 112M/15000iB

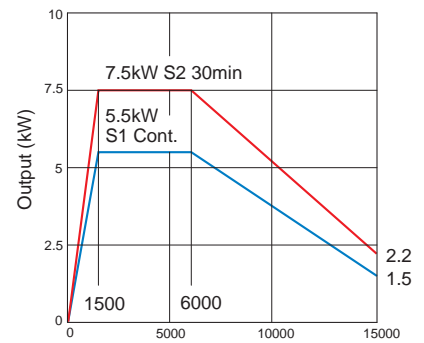

FANUC 112M/15000iB

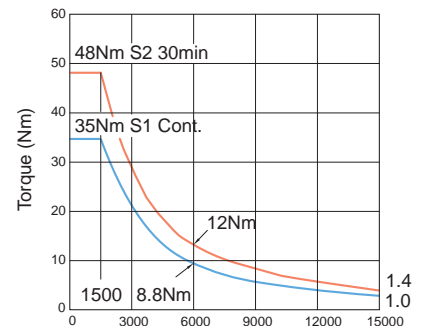

Power Turret Milling

FANUC 2.7kW 4000RPM

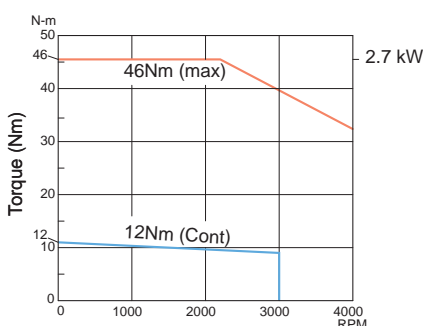

FANUC 4.5kW 6000RPM

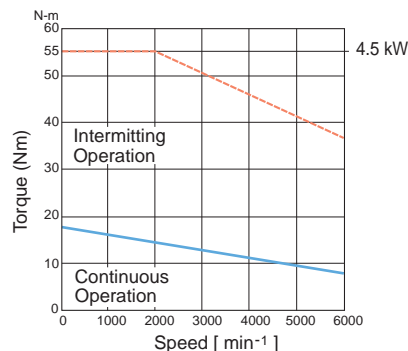

CF Axis (Opt.)

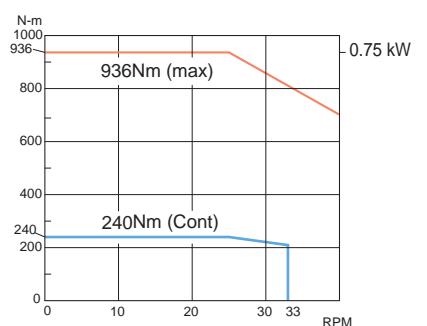

FNL-250Y / SY & FBL-250Y / SY Machining Zone

50mm X Axis Extension

Unit: mm

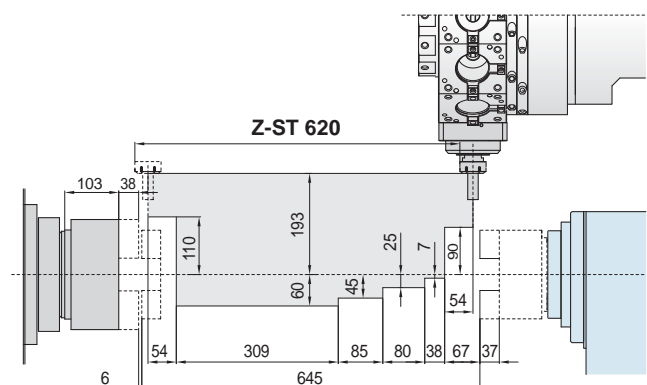
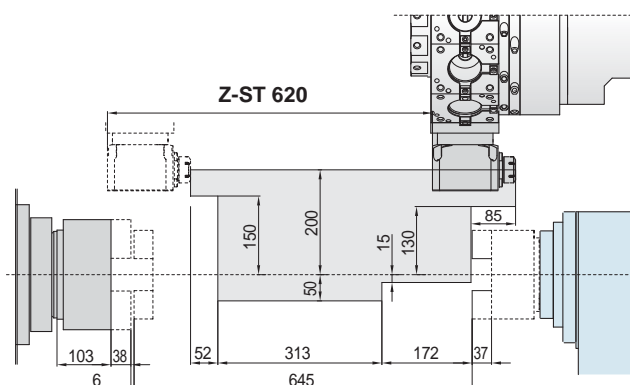
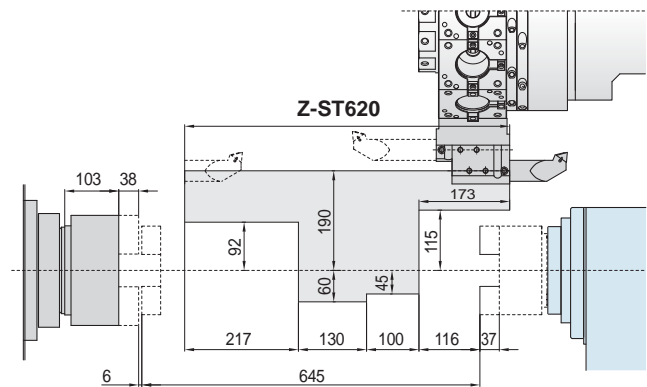
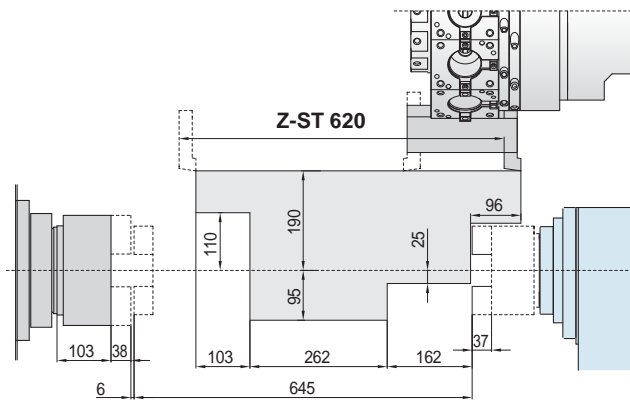
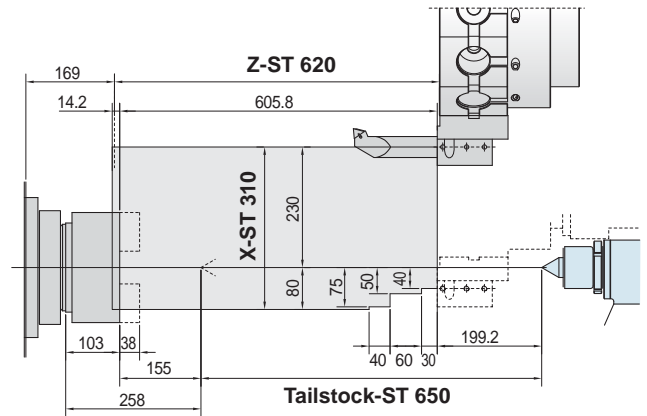
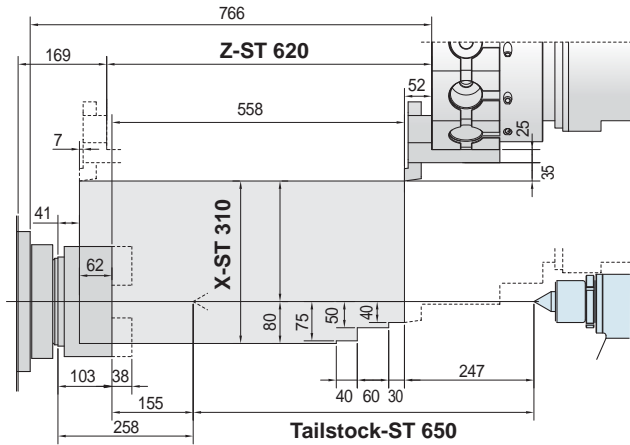
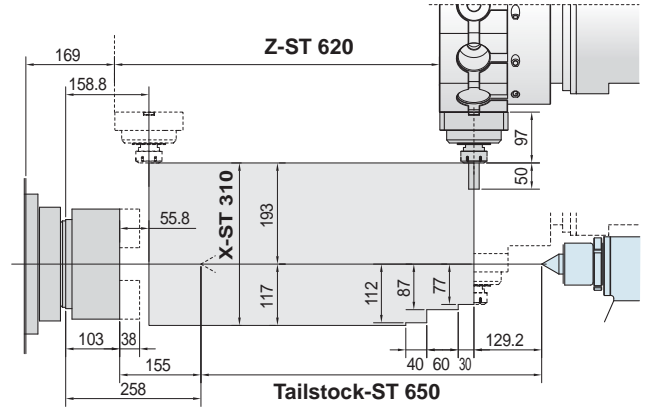
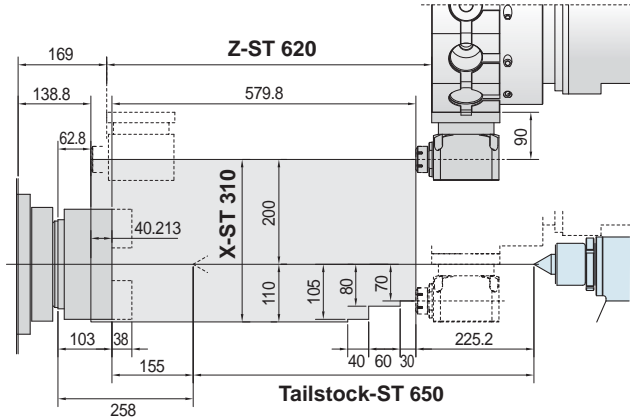

FNL-320Y / SY & FBL-320Y / SY Machining Zone

Unit: mm

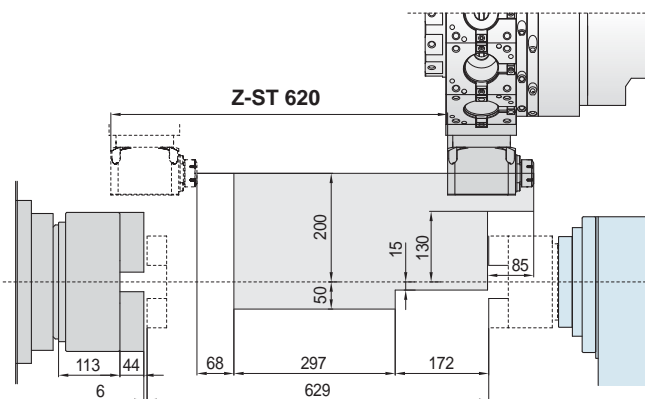
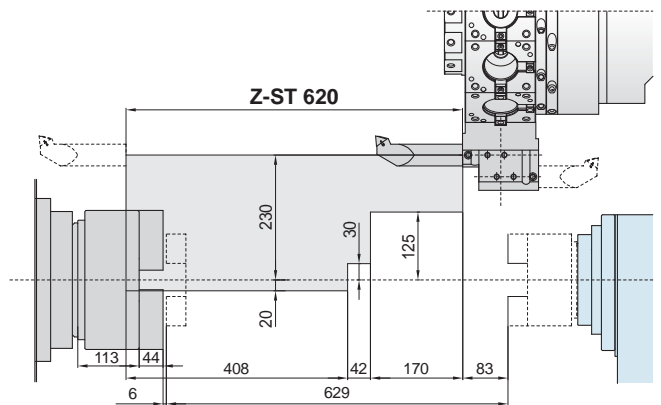
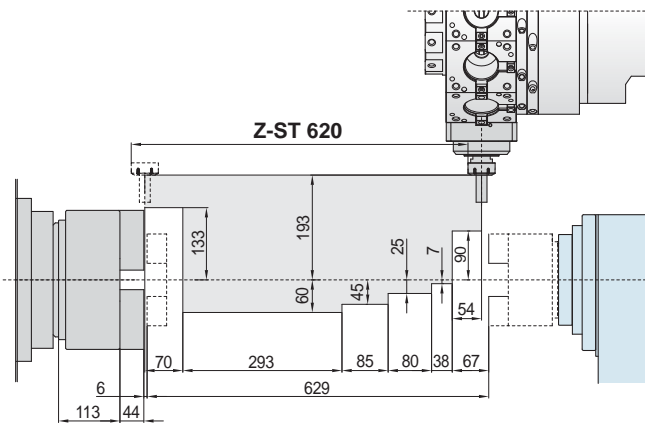
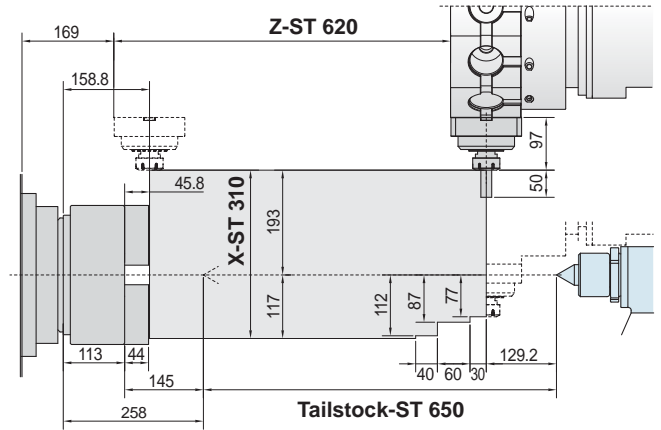
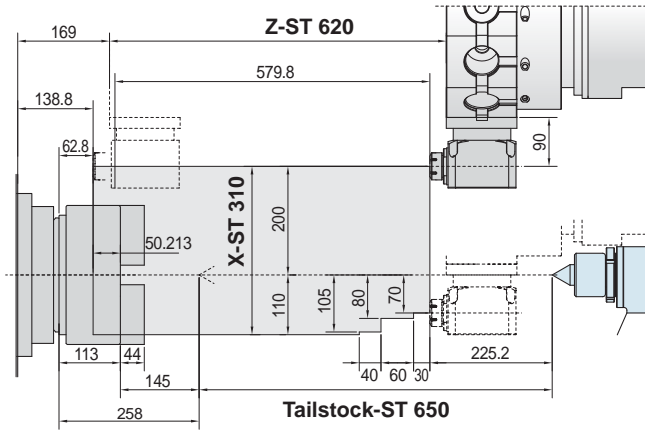
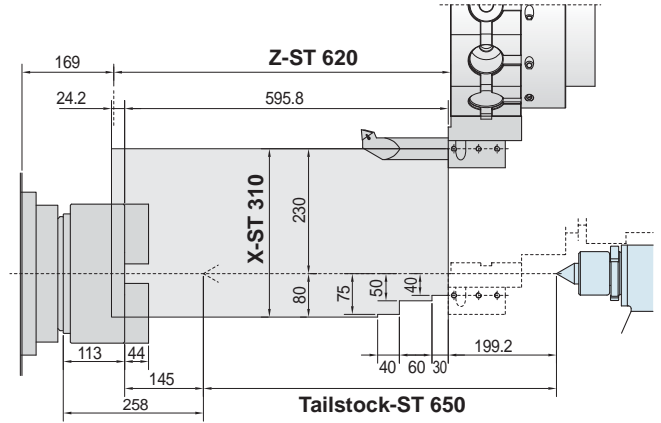
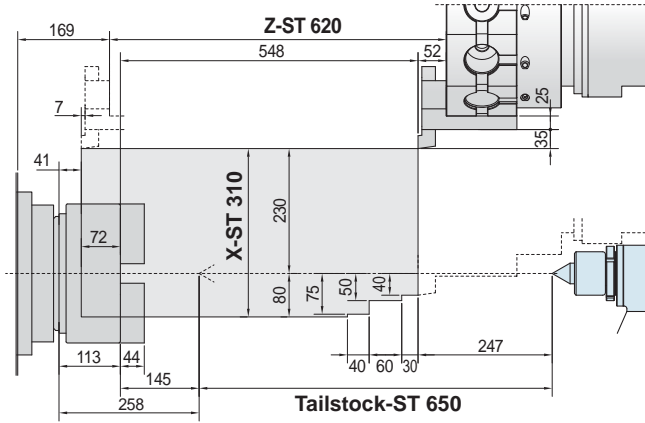

Specifications

MODEL		FNL-250Y FBL-250Y	FNL-250SY FNL-250SY	FNL-320Y FBL-320Y	FNL-320SY FBL-320SY
Chuck size	inch	8 (10)	8 (10)	10	10
Swing over bed	mm	600	600	600	600
Swing over cover	mm	600	600	600	600
Max. cutting diameter	mm	460	460	460	460
Max. cutting length	mm	558	558	548	548
Max. bar material diameter	mm	65	65	77	77
Axis travel	X axis	mm	310	310	310
	Y axis	mm	±55	±55	±55
	Z axis	mm	620	620	620
	ZB axis	mm	650	650	650
Main spindle	Max. spindle speed	rpm	4,500	4,500	3,500
	Spindle nose	ASA	A2-6	A2-6	A2-8
	Spindle hole diameter	mm	77	77	88
	Transmission		Belt	Belt	Belt
			Built-in (Optional)	Built-in (Optional)	Built-in (Optional)
Sub-spindle	Chuck size	inch	N/A	6"	N/A
	Max. spindle speed	rpm		6,000	
	Spindle nose	ASA		A2-5	
	Spindle hole diameter	mm		45	
	Transmission			Belt	
C axis positional accuracy		0.001°	0.001°	0.001°	0.001°
Turret		BMT 60	BMT 60	BMT 60	BMT 60
Number of tools	EA	12	12	12	12
Tool specifications	Turning tool size	mm	25	25	25
	Boring tool size	mm	40	40	40
Tool change time	sec.	0.2	0.2	0.2	0.2
Live tooling	Max. speed	rpm	4000 (6000)	4000 (6000)	6,000
	Motor power	kW	2.7 (46Nm)	2.7 (46Nm)	4.5 (55Nm)
Rapid traverse	X / Y axis	m/min	24 / 20	24 / 20	24 / 20
	Z / ZB axis	m/min	30 / 20	30 / 20	30 / 20
Tailstock	Quill taper hole		MT#4	-	MT#5
	Tailstock travel	mm	650	-	650
Spindle motors	Main spindle	kW	11 / 15	11 / 15	11 / 15
	Sub spindle	kW	-	5.5 / 7.5	-
Servo motors	X / Y axis	kW	2.7 / 2.7	2.7 / 2.7	2.7 / 2.7
	Z / ZB axis	kW	2.7 / 2.7	2.7 / 2.7	2.7 / 2.7
Voltage / Power	KVA	40	40	40	40
Machine weight	kg	5,700	5,800	6,500	6,600

■ Specifications are subject to change without notice.

Standard & Optional Accessories

● Standard △ Optional

MODEL	FNL-250 FBL-250		FNL-320 FBL-320	
	Y	SY	Y	SY
	8" Hydraulic chuck	●	●	-
10" Hydraulic chuck	△	△	●	●
6" Hydraulic chuck (sub spindle)	-	●	-	●
Hard jaws (set)	8"x1	8"x1	10"x1	10"x1
		6"x1		6"x1
Soft jaws (set)	8"x1	8"x1	10"x1	10"x1
		6"x1		6"x1
Boring bar holder	5	3	5	3
Bidirectional boring bar holder	-	2	-	2
Face holder	1	1	1	1
O.D. tool holder	3	3	3	3
Extended O.D. tool holder	3	3	3	3
Radial power tooling holder	△	△	△	△
Axial power tooling holder	△	△	△	△
Tool sleeve ø8~32 (set)	1	1	1	1
Coolant system	●	●	●	●
Moveable coolant tank	●	●	●	●
1 set leveling bolts and pads	●	●	●	●
Grease lubrication system	●	●	●	●
Centralizing lubrication system	△	△	△	△
Work lamp	●	●	●	●
3 color warning light	●	●	●	●
Foot pedal for hydraulic chuck	●	●	●	●
Tool kit	●	●	●	●
Hand wheel	●	●	●	●
Chip conveyor and bucket	●	●	●	●

MODEL	FNL-250 FBL-250		FNL-320 FBL-320	
	Y	SY	Y	SY
	High pressure pump 10 bar	●	●	●
MT4 / MT5 live center	●	-	●	-
Programmable tailstock	●	-	●	-
Servo tailstock	△	-	△	-
Parts catcher (main spindle)	△	△	△	△
Parts catcher (sub spindle)	-	△	-	△
Manual tool setting probe (main spindle)	△	△	△	△
Manual tool setting probe (sub spindle)	-	△	-	△
Auto tool setting probe (main spindle)	△	△	△	△
Oil skimmer	△	△	△	△
Oil mist collector	△	△	△	△
Transformer	△	△	△	△
CE safety accessories	△	△	△	△
CF axis	△	△	△	△
Manual guide i (Fanuc)	△	△	△	△
Shop turn (Siemens)	△	△	△	△
Automatic door (pneumatically driven)	△	△	△	△
Pedal switch for tailstock / sub spindle	△	△	△	△
Bar feeder and interface	△	△	△	△
Collet chuck	△	△	△	△

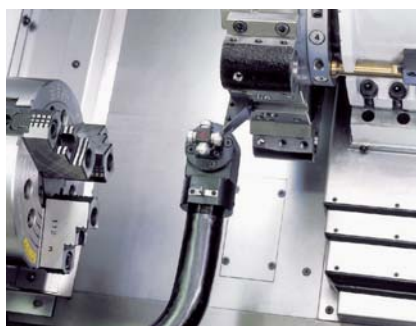

Manual, Auto Tool Setter



Parts Catcher



Bar Feeder



FOCUS CNC CO., LTD.

www.focuscnc.com.tw

No. 20-1, Alley 65, Lane 140, Dalin Road, Daya Dist., Taichung City 428, Taiwan

TEL: 886-4-2560-6067 FAX: 886-4-2567-7938 E-mail: focus@focuscnc.com.tw

Dimensions

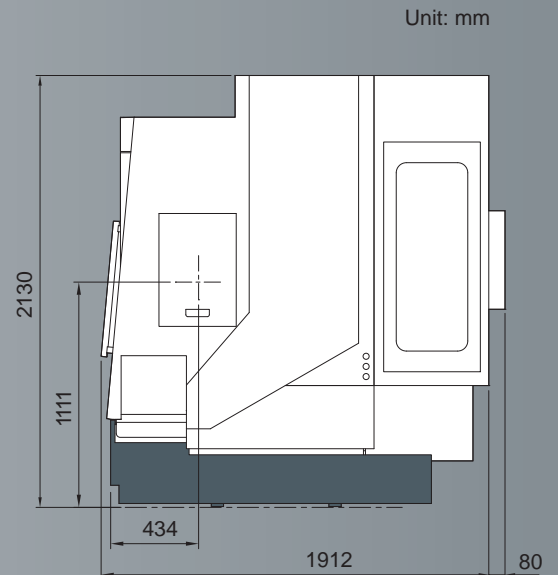
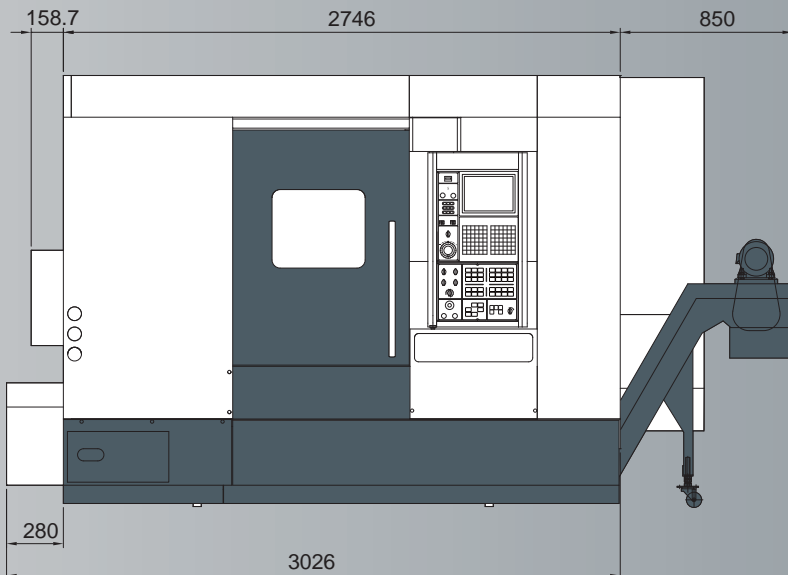
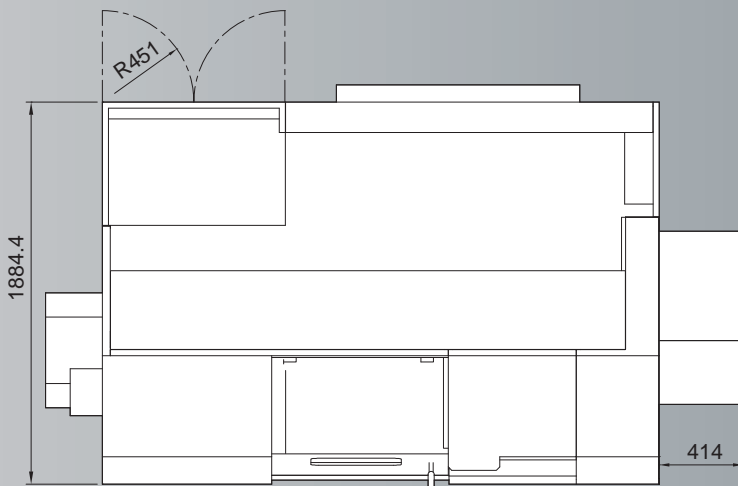

Unit: mm